

Ripped belt

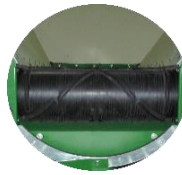

Special lacquering



Additional drawbar eye



Remote control



Rip blades



picture contains special options

Chute for 3rd fraction



Additional external wire screens optional 2 to 80 mm



Petrol power generator



LED lights

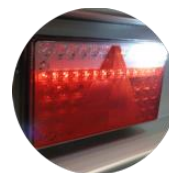

construction waste



green waste



wood chips



sand & gravel



recycling



stones



compost

ZEMMLER MULTI SCREEN® MS 1000 • Technical description

Base frame:

chassis: rubber spring axle
 tires: 2 x 195/70 R13C,
 load capacity each 900 kg
 brake: braking axle SB18

Feeder:

cubage: appr. 1 m³
 loading height: 2,000 mm
 loading length: 2,350 mm

Feeding belt:

belt width: 650 mm
 belt length: 2,000 mm
 belt type: smoother belt
 belt speed: dispatchable

Single trommel:

surface: 3 m² (outer screening)
 diameter: 900 mm
 length: 1,500 mm
 speed: 18 U/min
 drive: smooth start, not adjustable
 direct over belt pulleys

Cleaning brush:

diameter: 350 mm, self regular

Power:

electric drive (16A)
 power input approx. 5 kW (6,5 kVA) (standard)
 optional: Petrol power generator (not included)
 Prime power: 3.0 kW
 Tank capacity: 30l
 Weight: 90 kg
 Measures: 786 x 570 x 600 mm
For MS 1000 without additional electrical load

Weight: max. 1,800 kg

Hitch:

one hitch including, removable
 trailer hitch ball Ø 50 mm according ISO24347
 drawbar eye Ø 40 mm according ISO 8755

Dimensions:

Transportation:

length: 4,800 mm
 width: 1,900 mm
 height: 2,200 mm

Service:

length: 4,800 mm
 width: 2,900 mm
 height: 2,200 mm

Conveyor belt fine fraction:

belt width: 800 mm
 belt length: 1,760 mm
 belt type: smooth belt, mechanic fold-away
 drop off side: left
 drop off height: 1,400 mm
 profiled belt: possible

Capacity:

5 - 20 m³/hour
 depending on condition of material,
 mesh size and feeding

2 fractions:

fine fraction: 2 - 80 mm, on demand
 coarse fraction: up to a maximum 200 mm (standard)

Screen material:

sand, saw dust, wood chips, compost,
 construction waste and recycling materials,
 stones and gravel sand with grain size 2 - 80 mm

Colour / Coats:

2K polyurethane one-coat topcoat
 silo, engine cover and side covers: RAL 6001 green
 chassis, screening drum: RAL 7022 umbra grey
 conveyor belt frame: hot galvanized



construction waste



green waste



wood chips



sand & gravel



recycling



stones



compost

All details are subject to technical modifications and future developments.

Further distribution and any kind of publication is permitted only with written approval of the Zemmler Siebanlagen GmbH.

ZEMMLER MULTI SCREEN® MS 1000 • Dimensions service

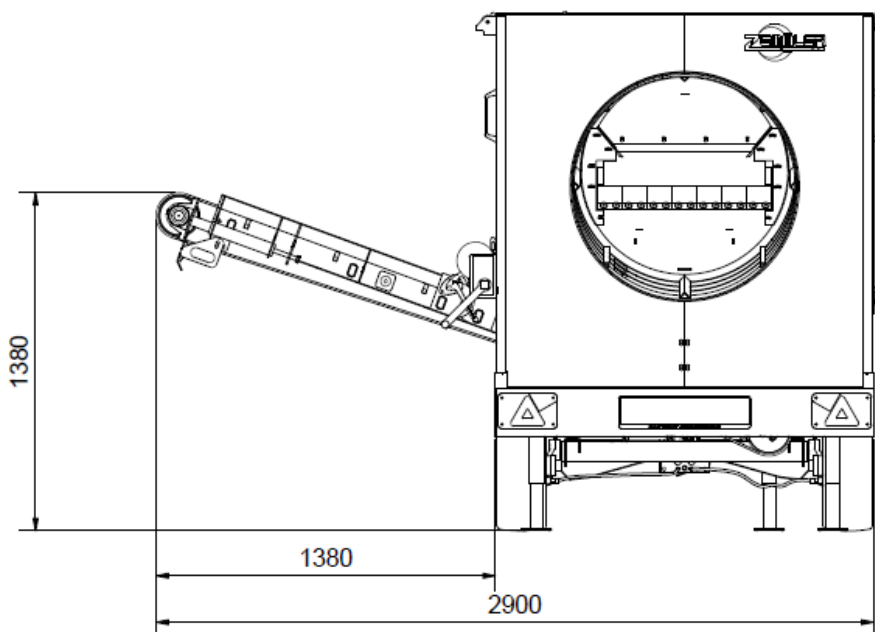
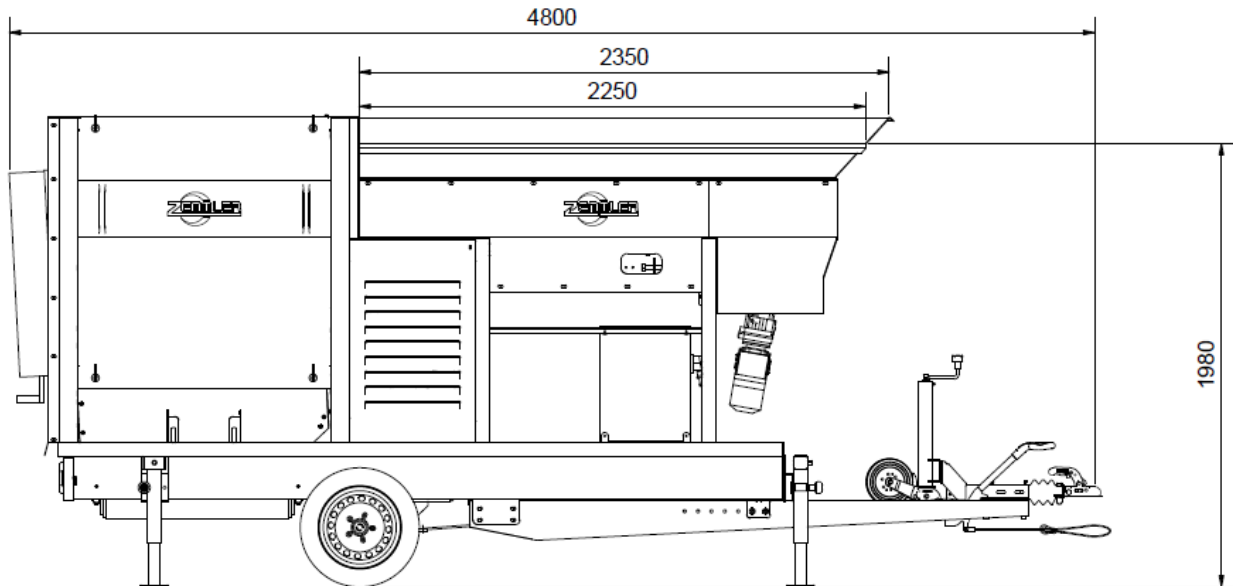

ZEMMLER MULTI SCREEN® MS 1000 • Dimensions transportation

